

Steel & Stainless Steel Flanged Safety Relief Valves

- Manufactured in accordance with ASME Code Section VIII
- NBBI capacity certified for Air/Gas
- Dependable “Ball & Seat” design
- Pressures to 3,700 psi
- 1” to 3” inlet sizes

 **Hydroseal**
Valve Company, Inc.



Flanged Safety Relief Valves

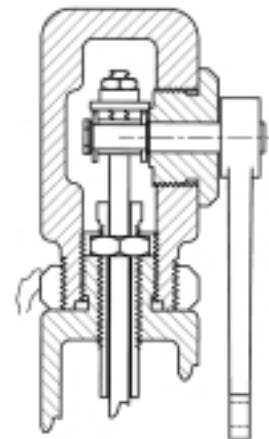
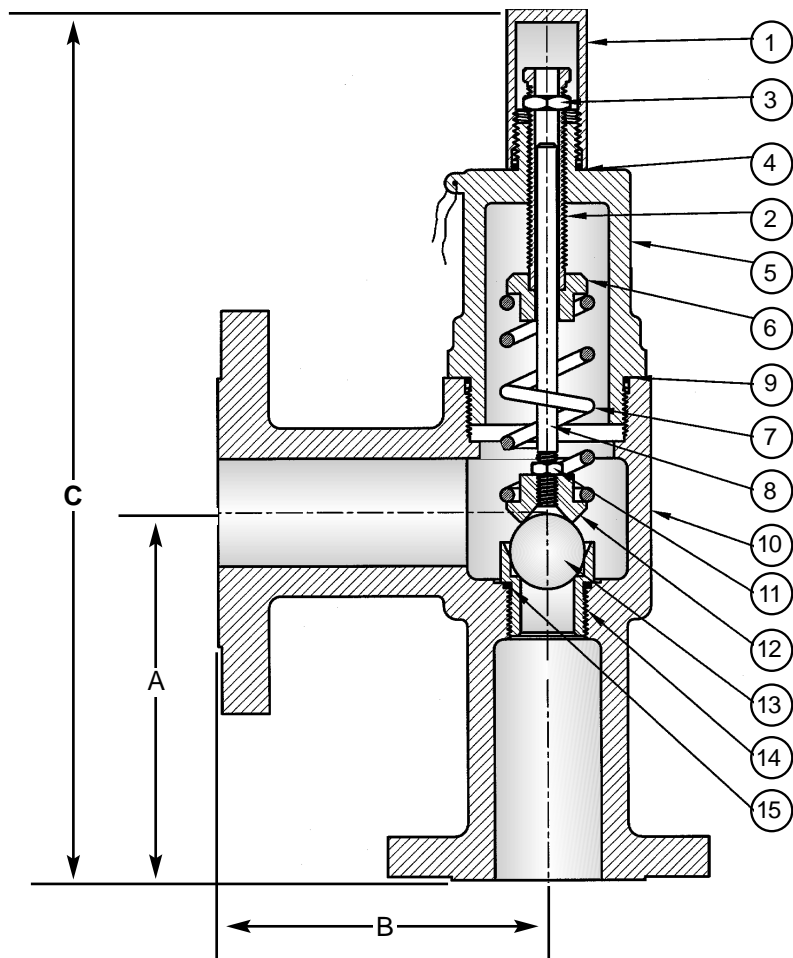

Packed Lift Lever

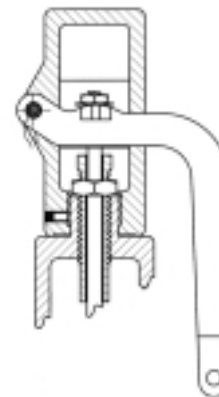

Open Lift Lever

MATERIAL CODE	0	1	2	3	4	5	6	7
1. VALVE CAP	CS	CS	CS	316 SS	316 SS	CS	CS	CS
2. ADJUSTING SCREW	CS	CS	CS	316 SS	316 SS	316 SS	316 SS	CS
3. ADJUSTING LOCKNUT	CS	CS	CS	316 SS	316 SS	316 SS	316 SS	CS
4. CAP SEAL	Nitrile	Nitrile	Nitrile	Viton®	Viton®	Viton®	Viton®	Nitrile
5. BONNET	WCB	WCB	WCB	C8FM	C8FM	WCB	WCB	WCB
6. UPPER SPRING PLATE	304 SS	304 SS	304 SS	316 SS	316 SS	316 SS	316 SS	304 SS
7. SPRING	CS	316 SS	302 SS	316 SS	Inconel®	316 SS	Inconel®	Inconel®
8. GUIDE STEM	SS	SS	SS	316 SS	316 SS	316 SS	316 SS	SS
9. BODY BONNET SEAL	Nitrile	Nitrile	Nitrile	Viton®	Viton®	Viton®	Viton®	Nitrile
10. BODY	WCB	WCB	WCB	CF8M	CF8M	WCB	WCB	WCB
11. STEM LOCKNUT	SS	SS	SS	316 SS	316 SS	316 SS	316 SS	SS
12. LOWER SPRING PLATE	SS	304 SS	304 SS	316 SS	316 SS	316 SS	316 SS	304 SS
13. BALL	440C	Stellite®	Stellite®	Stellite®	Stellite®	Stellite®	Stellite®	440C
14. SEAT	304 SS	304 SS	304 SS	316 SS	316 SS	316 SS	316 SS	304 SS
15. BODY/SEAT SEAL	Nitrile	Nitrile	Nitrile	Viton®	Viton®	Viton®	Viton®	Nitrile
OPEN LEVER ASSEMBLY	CS	CS	CS	Cast Stainless	Cast Stainless	CS	CS	CS
PACKED LEVER ASSEMBLY	CS	CS	CS	Cast Stainless	Cast Stainless	CS	CS	CS

CS - CARBON STEEL WCB - ASTM A 216 - WCB CARBON STEEL
 SS - STAINLESS STEEL CF8M - ASTM A 351 - CF8M STAINLESS STEEL

Viton® and Kalrez® are registered trademarks of the DuPont Dow Elastomers, LLC.
 Teflon® is a registered trademark of I. E. DuPont De Nemours Company.
 Stellite® is a registered trademark of the Deloro Stellite Company, Inc.
 Inconel® and Monel® are registered trademarks of the International Nickel Company, Inc.



1FL INLET • OUTLET

MODEL NO.	SIZE & RATING			DIMENSIONS			WEIGHT LBS.	
	INLET	FLANGE	OUTLET	FLANGE	A	B		C
1FL	1"	150	1"	150	5 1/2"	4 5/8"	12 3/4"	20
2FL	1"	150	1 1/2"	150	5 1/2"	4 5/8"	12 3/4"	24
3FL	1"	300	1 1/2"	150	5 1/2"	4 5/8"	12 3/4"	24
4FL	1"	600	1 1/2"	300	5 1/2"	4 5/8"	12 3/4"	28
5FL	1"	600	1"	150	5 1/2"	4 5/8"	12 3/4"	26
6FL	1"	600	1"	600	5 1/2"	4 5/8"	12 3/4"	28
7FL	1"	1500	1 1/2"	300	5 1/2"	4 5/8"	12 3/4"	28
8FL	1"	150	2"	150	5 1/2"	4 5/8"	12 3/4"	22
9FL	1"	300	2"	150	5 1/2"	4 5/8"	12 3/4"	26
10FL	1"	600	2"	150	5 1/2"	4 5/8"	12 3/4"	28
11FL	1"	600	2"	300	5 1/2"	4 5/8"	12 3/4"	30
13FL	1"	900	2"	150	5 1/2"	4 5/8"	12 3/4"	31
14FL	1"	900	2"	300	5 1/2"	4 5/8"	12 3/4"	34
20FL	1 1/2"	150	1 1/2"	150	6 3/4"	4 7/8"	15 1/2"	32
21FL	1 1/2"	150	2"	150	6 3/4"	4 7/8"	15 1/2"	34
22FL	1 1/2"	300	1 1/2"	150	6 3/4"	4 7/8"	15 1/2"	34
23FL	1 1/2"	300	2"	150	6 3/4"	4 7/8"	15 1/2"	36
24FL	1 1/2"	600	2"	150	6 3/4"	4 7/8"	15 1/2"	39
25FL	1 1/2"	600	2"	300	6 3/4"	4 7/8"	15 1/2"	42
26FL	1 1/2"	600	2 1/2"	150	6 3/4"	4 7/8"	15 1/2"	45
28FL	1 1/2"	900	2"	150	6 3/4"	4 7/8"	15 1/2"	50
29FL	1 1/2"	900	2"	300	6 3/4"	4 7/8"	15 1/2"	52
30FL	2"	150	2"	150	6 7/8"	6 1/8"	16 1/4"	44
31FL	2"	150	2 1/2"	150	6 7/8"	6 1/8"	16 1/4"	52
32FL	2"	150	3"	150	6 7/8"	6 1/8"	16 1/4"	56
33FL	2"	300	2 1/2"	150	6 7/8"	6 1/8"	16 1/4"	56
34FL	2"	300	3"	150	6 7/8"	6 1/8"	16 1/4"	40
35FL	2"	300	3"	300	8"	7 1/4"	16 1/4"	42
36FL	2"	600	2"	150	6 7/8"	6 1/8"	16 1/4"	45
37FL	2"	600	2"	300	6 7/8"	6 1/8"	16 1/4"	46
38FL	2"	600	2"	600	6 7/8"	6 1/8"	16 1/4"	50
39FL	2"	600	2 1/2"	150	6 7/8"	6 1/8"	16 1/4"	46
40FL	2"	600	2 1/2"	300	6 7/8"	6 1/8"	16 1/4"	48
41FL	2"	600	3"	150	6 7/8"	6 1/8"	16 1/4"	52
42FL	2"	1500	2 1/2"	300	8 1/8"	7 1/4"	16 1/4"	64
43FL	2"	1500	3"	300	8 1/8"	7 1/4"	16 1/4"	73
44FL	2"	1500	2"	300	8 1/8"	7 1/4"	16 1/4"	64
45FL	2"	1500	2 1/2"	600	8 1/8"	7 1/4"	16 1/4"	72
46FL	2"	900	3"	150	8 1/8"	7 1/4"	16 1/4"	74
47FL	2"	900	2"	300	8 1/8"	7 1/4"	16 1/4"	76
50FL	2 1/2"	150	2 1/2"	150	8"	7 1/4"	16 1/4"	66
51FL	2 1/2"	150	3"	150	8"	7 1/4"	16 1/4"	68
52FL	2 1/2"	300	3"	150	8"	7 1/4"	16 1/4"	70
53FL	2 1/2"	600	3"	150	8"	7 1/4"	16 1/4"	72
54FL	2 1/2"	600	3"	300	8"	7 1/4"	16 1/4"	72
60FL	3"	150	3"	150	8"	7 1/4"	16 1/4"	68
61FL	3"	300	3"	150	8"	7 1/4"	16 1/4"	70
62FL	3"	300	3"	300	8"	7 1/4"	16 1/4"	72
63FL	3"	600	3"	150	8"	7 1/4"	16 1/4"	74
64FL	3"	600	3"	300	8"	7 1/4"	16 1/4"	76
65FL	3"	150	4"	150	8"	7 1/4"	16 1/4"	74
66FL	3"	300	4"	150	8"	7 1/4"	16 1/4"	76
67FL	3"	600	4"	150	8"	7 1/4"	16 1/4"	78

1 FLANGE/FACING

INLET • OUTLET			
1	RF	x	RF
2	RF	x	RTJ
3	RTJ	x	RF
4	RTJ	x	RTJ

O-ring material selection is media and temperature dependent

ARV ORIFICE

ARV	- 1/2" Soft Seat
AXV	- 9/16"
BV*	- 3/4"
CV*	- 1"
CRV*	- 1" Soft Seat

**Not available on models 1FL to 14FL*

O MATERIAL CODE

0	- Standard Material
1	- Standard w/ 316 SS Spring, Stellite® Ball
2	- Standard w/ 302 SS Spring & Stellite® Ball
3	- All 316 SS w/ Stellite® Ball
4	- All 316 SS w/ Inconel® Spring & Stellite® Ball
5	- 316 SS Trim Stellite® Ball
6	- 316 SS Trim w/ Inconel® Spring
7	- Standard w/ Inconel® Spring

O CAP TYPE

0	- Closed Cap
L	- Open Lift Lever
P	- Packed Lift Lever

Maximum Temperature 450° F

ASME Code requires lift lever on water over 140° F and air except as allowed by ASME Code Case 2203

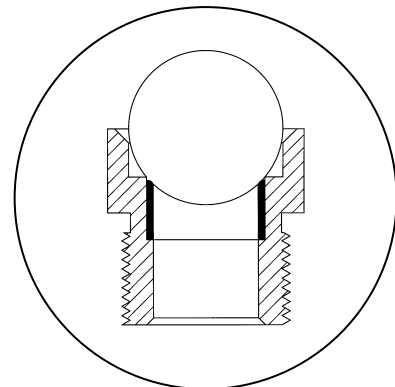

Soft Seat Detail
ARV & CRV Models
Molded Viton® seal standard
Optional materials available

Capacity Tables For Series 1FL TO 67FL



Set Pressure PSIG	ARV		AXV		BV		CRV		CV	
	Air SCFM	Water GPM	Air SCFM	Water GPM	Air SCFM	Water GPM	Air SCFM	Water GPM	Air SCFM	Water GPM
25	47	5	49	7	137	12	130	24	132	24
50	77	7	80	11	224	17	215	34	218	34
75	108	9	112	13	313	21	300	42	304	42
100	138	10	143	15	402	24	385	49	390	49
125	169	11	175	17	490	27	470	55	476	55
150	199	13	207	19	579	30	555	60	562	60
200	261	15	270	22	756	34	725	69	735	69
250	322	16	333	24	933	38	895	77	907	77
300	383	18	396	27	1110	42	1065	85	1079	85
350	444	19	460	29	1287	46	1235	92	1251	92
400	505	21	523	31	1464	49	1405	98	1423	98
500	627	23	649	35	1818	55	1745	110	1768	110
600	749	26	776	38	2173	60	2085	120	2112	120
750	932	29	946	42	2704	67	2595	134	2628	134
1000	1237	33	1282	49	3589	77	3444	155	3489	155
1250	1543	37	1598	55	4475	87	4294	173	4350	173
1500	1848	41	1914	60	5360	95	5144	190	5211	190
1750	2153	44	2231	65	6246	102	5994	205	6071	205
2000	2458	47	2547	70	7131	110	6843	220	6932	220
2500			3179	78	8902	123				

ASME Section VIII "UV" Code for Air/Gas

AIR CAPACITIES listed at 10% over set pressure.

To calculate air capacities in SCFM, $Q = m[(1.1 \times \text{Set Pressure PSI}) + 14.7]$

m [slope] VALUES

ORIFICE	DIA.	SLOPE
ARV	1/2"	1.11
AXV	9/16"	1.15
BV	3/4"	3.22
CRV	1"	3.09
CV	1"	3.13

WATER CAPACITIES determined at 25% over set pressure

MAX. SET PRESSURE must not exceed the lesser of flange pressure class rating or maximum orifice pressure

CANADIAN REGISTRATION NUMBER 0G0736.2C

(Applies to ASME Code stamped valves only.)



P.O. Box 1382 • Kilgore, Texas 75663-1382
903-984-8574 • Fax 903-984-6307
www.hydroseal.com

