



CONTENTS

1.0 GENERAL	
1.1 Model Number	2
1.2 Specifications	3
1.3 Dimensions	4
2.0 CALIBRATION PROCEDURE	4
3.0 Adjustments	
3.1 Manual Set Point	5
3.2 Proportional Band	5
3.3 Reset (Model 3360)	6
4.0 Maintenance	
4.1 Replacing Gauges	6
4.2 Replacing Bourdon Tube	6
4.3 Changing Proportional	6
4.4 Changing Reset	6
4.5 Changing Action	6
4.6 Relay Replacement	7
4.7 Relay Disassembly	8
4.8 Relay Assembly	8
4.9 Changing Output Signal Range	8

Model 3350 / 3360

Installation, Operation and Maintenance Instructions

1.0 GENERAL

1.1 Model Number Information

Sample Model Number: 3350 - 010 R 1 - 0

CONTROLLER MODE		CODE
Proportional		50
Proportional-plus-Reset		60
INPUT SIGNAL RANGE		CODE
0 to 30 psig (0 to 2 bar)		003
0 to 60 psig (0 to 4 bar)		006
0 to 100 psig (0 to 7 bar)		010
0 to 200 psig (0 to 14 bar)		020
0 to 300 psig (0 to 20 bar)		030
0 to 600 psig (0 to 40 bar)		060
0 to 1000 psig (0 to 70 bar)		100
0 to 1500 psig (0 to 100 bar)		150
0 to 3000 psig (0 to 200 bar)		300
CONTROLLER ACTION		CODE
Direct (Increase output on increasing pressure)		D
Reverse (Decrease output on increasing pressure)		R
CONTROLLER OUTPUT		CODE
3-15 psig (0.2 to 1.0 bar)		1
6-30 psig (0.4 to 2.0 bar)		2
MOUNTING		CODE
None		-
NACE Compliant for Sour Gas Service		N
OPTIONS		CODE
None		0
Actuator Yoke		1
Actuator Housing		2
Panel		3
2-inch Pipestand		4
Surface (Wall)		5

1.2 Specifications

Controller Configurations

Proportional	(Model 3350)
Proportional-plus-Reset	(Model 3360)

Input Signal (Bourdon Tube Ranges)

0 to 30 psig	(0 to 2 bar)
0 to 60 psig	(0 to 4 bar)
0 to 100 psig	(0 to 7 bar)
0 to 200 psig	(0 to 14 bar)
0 to 300 psig	(0 to 20 bar)
0 to 600 psig	(0 to 40 bar)
0 to 1000 psig	(0 to 70 bar)
0 to 1500 psig	(0 to 100 bar)
0 to 3000 psig	(0 to 200 bar)

Output Signal

3 to 15 psig	(0.2 to 1.0 bar)
6 to 30 psig	(0.4 to 2.0 bar)

Controller Action

Direct	(Increase output on increasing pressure)
Reverse	(Decrease output on increasing pressure)

Input, Supply, and Output Connections

¼" FNPT

Supply Pressure Requirements

Type:	Clean, dry air or non-corrosive gas ¹
Normal Operating Supply Pressure ² :	
3 to 15 psig output:	20 psig (1.4 bar)
6 to 30 psig output:	35 psig (2.4 bar)
Maximum Allowable Supply Pressure:	
3 to 15 psig output:	40 psig (2.8 bar)
6 to 30 psig output:	40 psig (2.8 bar)

Steady-State Air (Gas) Consumption¹

Minimum ³ :		
3 to 15 psig output:	4.2 scfh	
6 to 30 psig output:	7 scfh	
Maximum ⁴ :		
3 to 15 psig output:	27 scfh	
6 to 30 psig output:	42 scfh	

Performance

Repeatability:	0.5% of bourdon tube range
Dead Band:	0.1% of output span

Controller Tuning Adjustment Ranges

Proportional (full output pressure change):	
3 to 15 psig output:	3–100% of input range
6 to 30 psig output:	6–100% of input range
Reset:	Adjustable from 0.01 to 74 minutes per repeat (100 to 0.01 repeats per minute)

Maximum Allowable Static Pressure

Same as bourdon tube upper range value

Operating Temperature Limits

-40 to 160°F (-40 to 71°C)

Construction Materials

See Table 1

Mounting

Actuator Yoke, Actuator Housing, Panel, Surface (Wall), or 2-inch Pipestand

1. If the supply gas is flammable or noxious, the controller must be located in a well-ventilated, non-hazardous area.
2. If this pressure is exceeded, control performance may be impaired.
3. At proportional band setting of 0 or 10.
4. At proportional band setting of 5.

Model 3350 / 3360

Installation, Operation and Maintenance Instructions

1.3 Dimensions

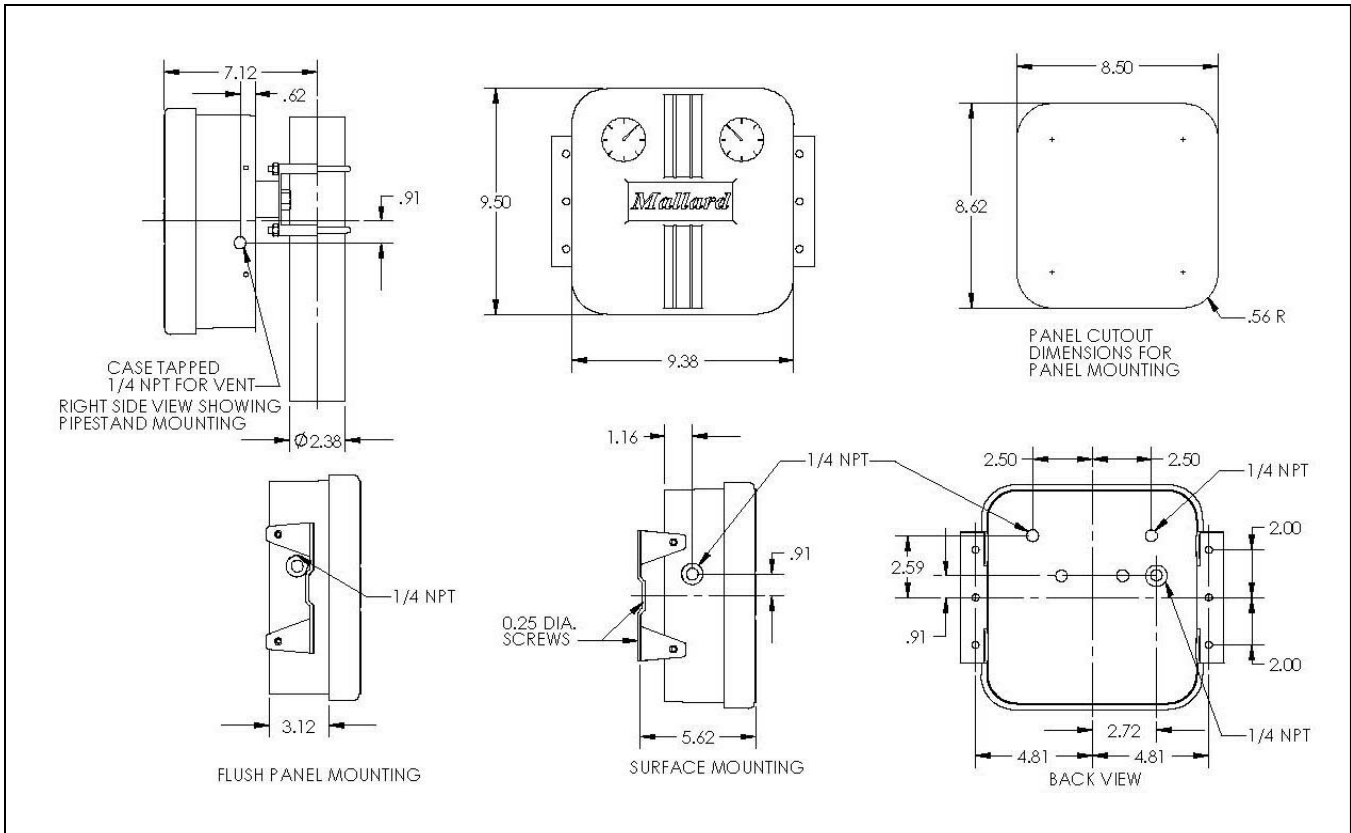

2.0 Calibration Procedure

1. It is recommended to calibrate the controller in the position it will be operated in.
2. Determine supply pressure requirement by checking controller output signal range. (Example, an output signal range of 6-30 psi (40-200 KPa) would require 35 psi (240 KPa) supply pressure). See table 2.
3. Connect supply pressure to the SUPPLY connection at the back of the case.
4. Install 1/4" NPT pipe plug at the OUTPUT connection at the back of the case. (The controller output pressure is dead-ended into the pressure gauge.)
5. Connect supply pressure to the CONTROL pressure block (compressed air is recommended) equivalent to the bourdon tube rating. Note: Connection to the control pressure block is either to the CONTROL connection in the back of the case or to the connection at the left side of the case. Plug the unused connection.
6. Rotate proportional band knob and set at 1.5 (15% proportional band). For Model 3360, rotate reset restrictor valve to set at MAX. (Note: If the reset restrictor valve is to be left on MAX. setting, the controller will operate like a proportional-only (Model 3350) controller, in which case Mallard recommends removing the reset module.)
7. Apply supply pressure. Do not exceed normal operating supply pressure (table 2) and maximum bourdon tube rating respectively.

8. Slightly push flapper upwards (for direct-acting controller) or downwards (for reverse-acting controller). Regardless of controller action, output pressure must be equal to supply pressure.
9. Inspect the following for leaks.

Model 3350 Controller

- Relay and relay base
- All tubings and connections (relay & compensator)
- Bellows, bellows frame and bellows screws
- Proportional band

Model 3360 Controller

- Relay and relay base
- All tubings and connections (relay & compensator)
- Bellows, bellows frame and bellows screws
- Proportional band
- Reset restrictor valve
- Reset and compensator tubings

10. Verify that the calibration adjuster screws are at mid-point in the calibration adjuster.
11. Verify that the proportional band is set at 1.5. For Model 3360, verify that the reset restrictor valve is set at 0.01 minutes per repeat. Rotate proportional band knob and/or reset restrictor valve knob to proper setting accordingly.
 - a. Rotate and set pressure setting knob to zero.
 - b. Apply supply pressure based on output signal range requirement (i.e., 35 psi supply pressure for a 6-30 output signal range requirement). See table 2.
 - c. Output gauge should read between 8 and 10 psi. If not, adjust the nozzle until output pressure is between 8 and 10 psi.
 - d. Apply input pressure equal to the bourdon tube maximum rating.
 - e. Rotate pressure setting knob to the maximum value which is equal to the bourdon tube rating.
 - f. Output gauge reading should be between 8 and 10 psi. If not, adjust controller span by loosening one of the two calibration adjuster screws and move the calibration adjuster a small distance as explained below and illustrated in figure 7.
 - **For direct-acting controller** – If output is below 8 to 10 psi, move calibration adjuster to the left. If output is above 8 to 10 psi, move calibration adjuster to the right.
 - **For reverse-acting controller** – If output is below 8 to 10 psi, move calibration adjuster to the right. If output is above 8 to 10 psi, move calibration adjuster to the left.
12. Repeat steps “c” through “f” until output gauge reads between 8 and 10 psi on both zero and maximum value pressure setting is achieved.

3.0 Adjustments

- 3.1 **Manual Set Point**
Adjust the pressure–setting knob by turning the knob to the desired pressure.
- 3.2 **Proportional Band**
May be adjusted to the sensing element range from 3-100%. The proportional band controls the percentage of sensed pressure change required to cause the valve to fully stroke.
- 3.3 **Reset (Model 3360)**
The reset allows an output change to occur causing a reset action. Turning the adjustment knob counter-clockwise increases the reset action speed. The minutes per repeat indicate the time

Model 3350 / 3360

Installation, Operation and Maintenance Instructions

required for the output changes from the reset to equal the output change from the proportional band.

4.0 Maintenance

WARNING: The following maintenance procedures require taking the controller out of service. To avoid personnel injury, the following procedures should be performed only by a qualified technician. Always ensure the controller is fully released of pressure or process fluid before starting maintenance.

If the installation includes a supply regulator, periodically open the drain on the filter regulator to drain accumulated moisture.

Also, push the cleaner wire on the relay orifice.

Inspect the opening of the vent assembly or the opening of the remote vent pipe, if one is used. If necessary, clean the openings.

4.1 Replacing Gauges

3350 / 3360 controllers require two gauges. Always be sure to check the range of the controller before ordering gauges (e.g. 0-30 psi gauges will not work on 6-30 controllers).

4.2 Replacing Bourdon Tube

1. **WARNING: Isolate process connection line prior to disconnecting bourdon tube from control tubing. Be aware of potential hazards from disconnection process connections.**
2. Disconnect beam screw.
3. Disconnect control tubing.
4. Remove screws and washers.
5. Disconnect the link screw from the bourdon tube. (Note: The bearings are easy to lose – be careful!)
6. Repeat steps 2 to 5 in reverse to install a new tube. Ensure the beam is reasonably parallel with the bottom of the case. This can be adjusted by loosening the screws holding the bourdon tube and rotating it until the beam is parallel, then retighten the screws. (Note: The link should have some tension from beam / bourdon tube relationship. If the bourdon tube is a different range a new dial will be required).
7. To replace the dial remove the screw and washer.
8. Check all tubing connections and recalibrate.

4.3 Changing Proportional

1. Disconnect tubing and unscrew by turning counterclockwise. Ensure to use proper thread sealant when reinstalling. Never over-torque!
2. Reconnect tubing and check for leaks.

4.4 Changing Reset

1. Disconnect tubing and remove the reset mounting screw (Access from back of the controller).
2. Reinstall, reconnect the tubing and check for leaks.

4.5 Changing Action

1. Shut off and bleed all supply connections, isolate process connections.
2. Relocate the reversing block.
3. With the nozzles in the reversing block, adjust the nozzle block screw as required.

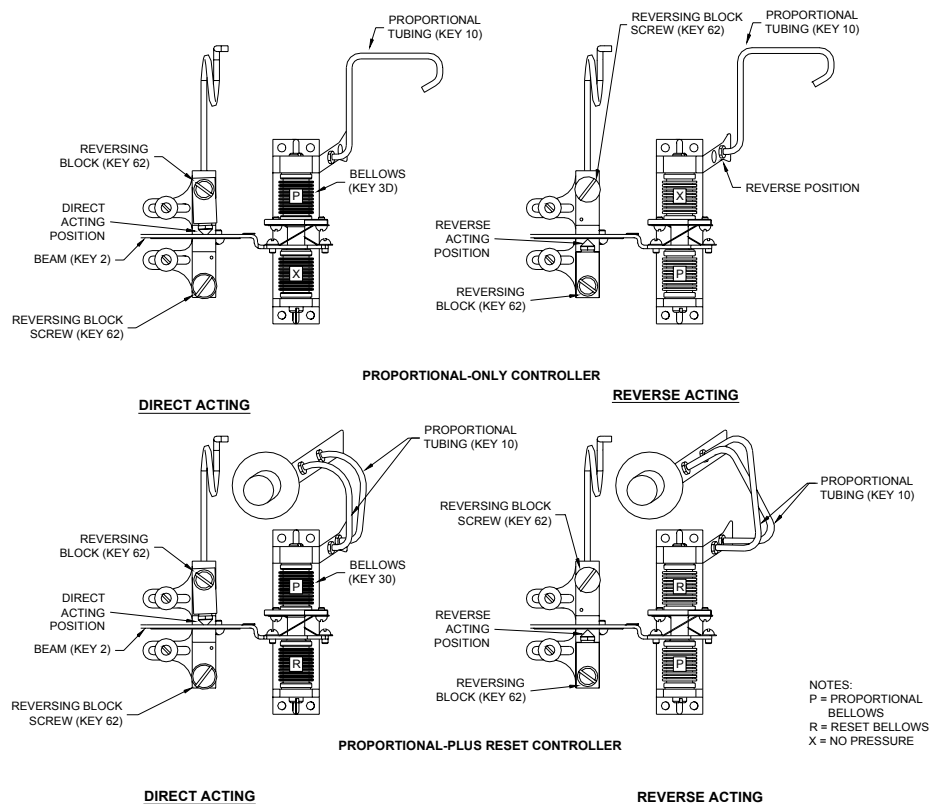

Figure 7. Direct/Reverse Acting Tubing Connections

4. **For a proportional-only controller with manual set point**, disconnect the proportional tubing from the mounting base and reconnect it in the opposite hole.
 5. **For a proportional-plus-reset controller**, disconnect the proportional tubing and reset tubing from the mounting base and reconnect them in the opposite hole.
 6. Remove the reversing block screw and reversing block assembly. Inspect the o-rings located in the recessed area under the reversing block screw head, between the reversing block assembly, and the calibration adjuster. Replace these o-rings, if necessary.
 7. Position the reversing block assembly, with o-ring, on the calibration adjuster so that the nozzle is on the opposite side of the beam from which it was removed. Properly position the reversing block assembly so that the alignment pin engages the hole in the calibration adjuster. Install the reversing block screw with o-ring.
 8. Install the sealing screw with o-ring in the hole previously covered by the reversing block assembly.
 9. Install the relay tubing in the reversing block.
 10. Check all the connections for leaks with leak detector solution. Perform the calibration procedure.
- 4.6 Relay Replacement
1. Always shut down the supply pressure and process pressure line(s) to the controller.
 2. Disconnect the tubing from the relay.
 3. Unscrew the output or supply pressure gauge.
 4. Remove the relay gasket.
 5. Attach the replacement relay and new relay gasket, reinstall the output or supply gauge.

Model 3350 / 3360

Installation, Operation and Maintenance Instructions

6. Connect the tubing, and check all connections for leaks. Perform the calibration procedure.

4.7 Relay Disassembly

1. Unscrew the orifice assembly. Remove the O-ring from the orifice assembly.
2. Remove the casing screws, casing assembly, and top diaphragm.
3. Remove the spacer ring, diaphragm assembly, and relay spring from the relay body.
4. Remove the screws, spring plate, spring plate gasket, spring, and valve plug.
5. Inspect the valve seats for roughness due to corrosion. One seat is located in the diaphragm assembly, and the other seat is located in the relay body.

4.8 Relay Assembly

1. Replace the diaphragm assembly or relay body if necessary. Inspect the diaphragms and gaskets, and replace them if necessary. Also replace the spring and valve plug if they show signs of corrosion. The lower diaphragm is part of the diaphragm assembly and must be replaced as an assembly. Clean all parts thoroughly before re-assembling.
2. Place the relay spring in the relay body. Install the diaphragm assembly, spacer ring, and top diaphragm on the body so that all flow passage holes are lined up.
3. Put the casing assembly on the top diaphragm so that the lugs on the casing and spacer ring line up and are also lined up with the body lug.
4. Install the casing screws, but do not tighten them.
5. Tighten the casing screws evenly.
6. Install the valve plug, spring, gasket, and cover plate. Secure with the machine screws.
7. Install the o-ring on the orifice assembly, and install the orifice assembly into the relay casing.

4.9 Changing Output Signal Range

1. Use the following procedures when changing the output signal range on the controller from a 3 to 15 psig (20 to 100 kpag) or a 6 to 30 psig (40 to 200 psig) output signal range or vice versa.
2. Always shutdown the supply pressure and process lines to the controller.
3. Disconnect the tubing from the mounting base, and calibration adjuster.
4. Disconnect the tubing that connects the pressure block to the bourdon tube or bellows assembly at the pressure block end.
5. Unscrew the machine screws, and remove the subassembly from the case.
6. Disconnect the bourdon tube from the beam by removing the screw. Be careful to avoid losing the bearing. Unscrew the machine screws, and remove the washers and bourdon tube.
7. Unscrew the bellows screws from each end of the mounting base. Remove the o-ring and replace.
8. Compress the bellows so that the end of the bellows and beam can be removed from the end of the mounting base.
9. With the stud that connects the two bellows in place in the spacer screw the new bellows onto the stud. Install new gaskets on each bellows.
10. Compress the bellows, and install them into the mounting base. With the beam parallel with the mounting base, secure the bellows with the bellows screws.
11. After tightening the bellows screws, make sure that the nozzle is centered on the flapper.
12. Replace the subassembly in the case and secure with the machine screws. Install the bourdon tube if it was removed – refer to the Replacing bourdon tube section if required, reconnect all tubing.
13. Unscrew the supply and output gauges, and install new gauges with correct ranges.
14. Check all tubing connections and the bellows machine screws for leaks. Tighten as necessary. Perform the calibration procedure.