

The Model 3100E is an electric, float-operated switch which can be used as a high or low level alarm or for liquid level control. The 3100E is rated for high pressure applications, and the polystyrene float will effectively and consistently operate the switch at specific gravities as low as 0.50. The switch can be mounted directly onto the vessel nozzle or into an external float chamber (Figure 1).

Specifications

Process Connection:	2" MNPT
Max Operating Pressure:	2000 psig (138 Bar)
Temperature Limits:	-20 to 300°F (-29 to 200°C) -20 to 400°F (optional) -40 to 200°F (optional)
Minimum Operating SG:	0.50 (Polystyrene Float) 0.68 (316 SST Float)
Approvals:	UL - Class I, Groups C and D
Switch Rating/Wiring:	See Figure 2
SPDT Switch Rating:	5 A @ 125-250-480 VAC 1/2 A @ 125 VDC 1/4 A @ 250 VDC 2 A @ 6-30 VDC Resistive 1 A @ 6-30 VDC Inductive
DPDT Switch Rating:	10 A @ 125-250 VAC 1/2 A @ 125 VDC 1/4 A @ 250 VDC 10 A @ 6-24 VDC Inductive/Resistive
Leadwires:	18 AWG x 36" Long

Materials of Construction

- Body: 1018 Carbon Steel / plated
316 SST (optional)
- Float: Polystyrene
316 SST (optional)
- Seals: Viton or Buna

Replacement Parts

31126	Polystyrene Float
31128	Optional SST Float
31106	Switch Assembly, SPDT
85086	Switch Assembly, DPDT

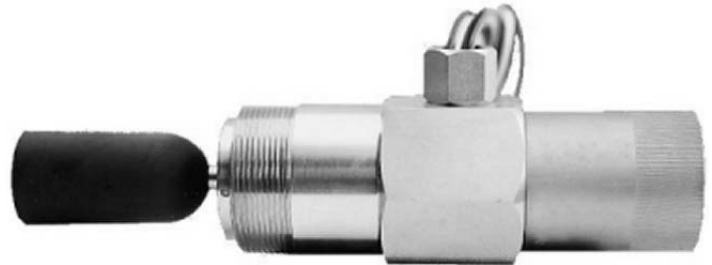

Standard Model	Description
3100E	SPDT Switch - CS Body
3100E2	DPDT Switch - CS Body
3100E-SS	SPDT Switch - 316 SST Body
3100E2-SS	DPDT Switch - 316 SST Body

Options	
Part Number	Description
31128	SST Float (0.68 SG min)
31124	External Float Chamber (Figure 1)
31130	1" Float Extension
-	High Temp (-20 to 400°F)
-	Low Temp (-40 to 200°F)
-	NACE

Dimensions:

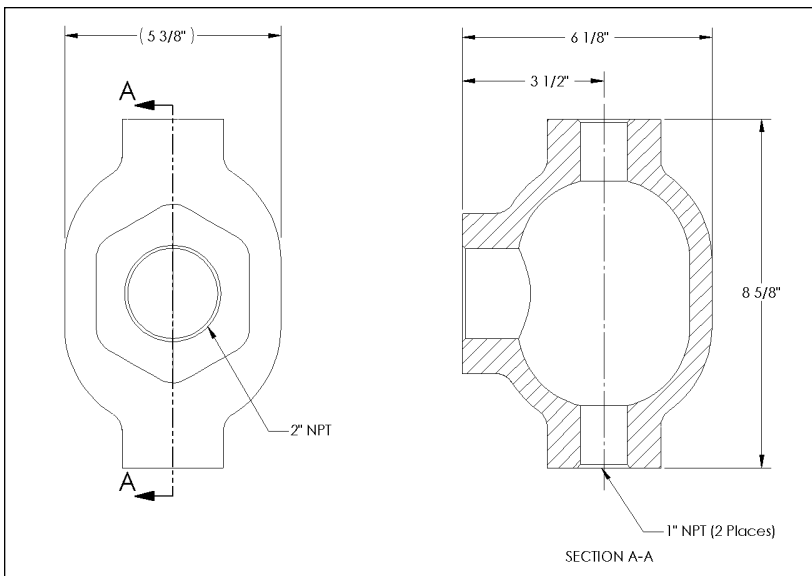
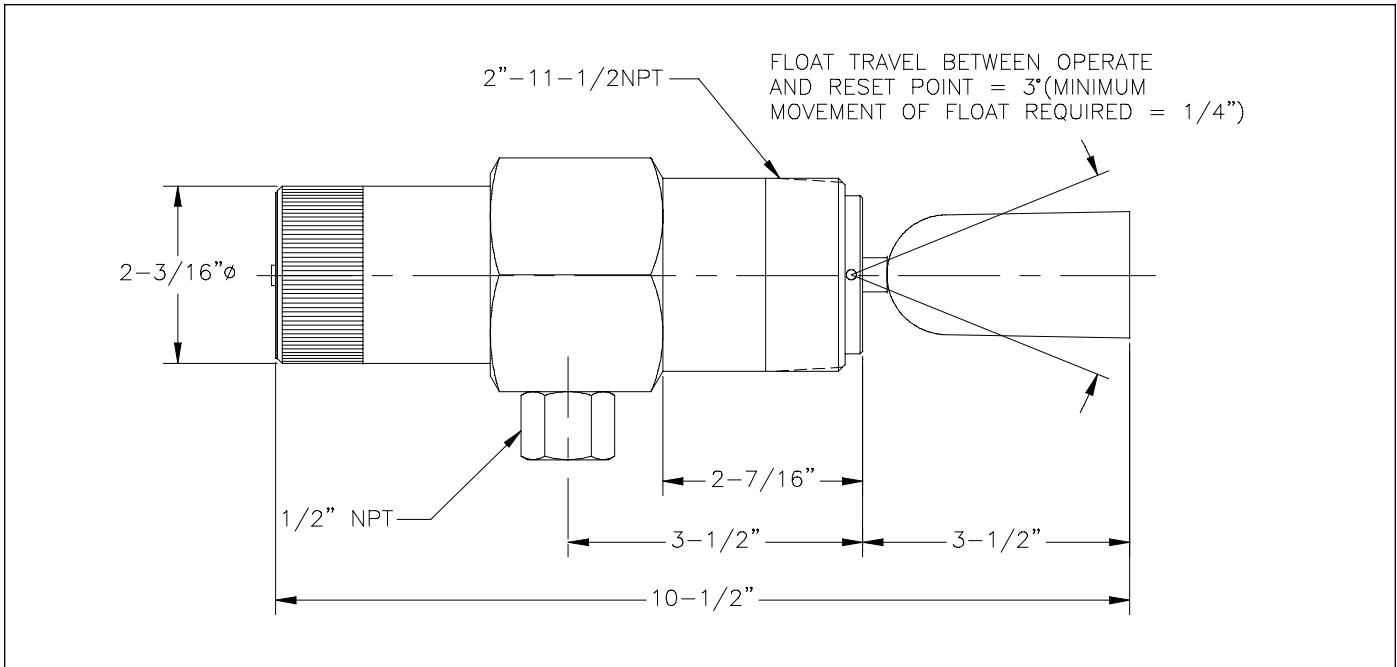

Figure 1. External Float Chamber

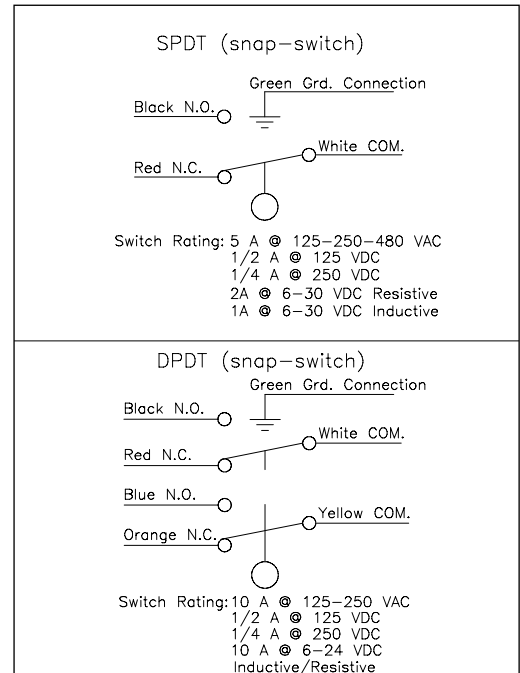

Figure 2. Switch Rating and Wiring

While this information is presented in good faith and believed to be accurate, Mallard Control Company does not guarantee results based upon such information. Mallard Control Company reserves the right to change the design or specifications of these products without notice.

Mallard Control Company, Inc.

4970 Washington Boulevard
 Beaumont, Texas, USA 77707
 409 842-5392 Phone
 409 842-8165 FAX
 www.MallardControl.com