

Specifications:

3100P, 3100P1 & 3100E

Process Connections: 2" MNPT
Max. Operating Pressure: 1500 psig (103 Bar)
Operating Temp.: -20 to 300°F (-29 to 200°C)
Minimum Operating Specific Gravity:

- 0.50 (Polystyrene Float)
- 0.68 (316 SST Float)

Materials of Construction:

- Body: 1018 Carbon Steel / plated
316 SST (optional)
- Float: Polystyrene
316 SST (optional)
- Seals: Viton

3100P & 3100P1

Supply Pressure Connection: 1/8" FNPT
Exhaust Connection: 1/4" FNPT
Supply Pressure: 30 to 60 psig

3100E

Switch Rating: See Figure 4
Leadwires: 18 AWG x 36" Long

Installation

A. Into Pressure Vessel Wall

1. Make sure the lock washer is in place. Secure the float and extension to the level switch.

Caution: Do not use more than one extension.

2. Make sure the travel requirements of Figure 3A and 3B are met.
3. Screw the 3100 directly to the vessel using proper screwed connection techniques.
4. The 3100E's electrical connection should face the bottom. The 3100P and 3100P1 pneumatic connection should be on top.
5. Make electrical connections following National Electrical Code and UL guidelines.
6. Fully install cap.

B. Into an External Chamber (Figure 2)

1. Install external chamber on the outside wall of the vessel using 1" NPT pipe and fittings. The 2" NPT connection must face away from the vessel.
2. Install the 3100 into the external chamber following the procedures for install a level switch into a pressure vessel wall.

C. 3100P & 3100P1

1. Supply pressure must be between 30 and 60 psig. The pneumatic source should be clean and dry. Debris and wet gas will hinder the operation of the level switch. A filter-regulator should be installed before the input to the switch.
2. If the signal gas begins to leak, adjust the level switch per Figure 1.

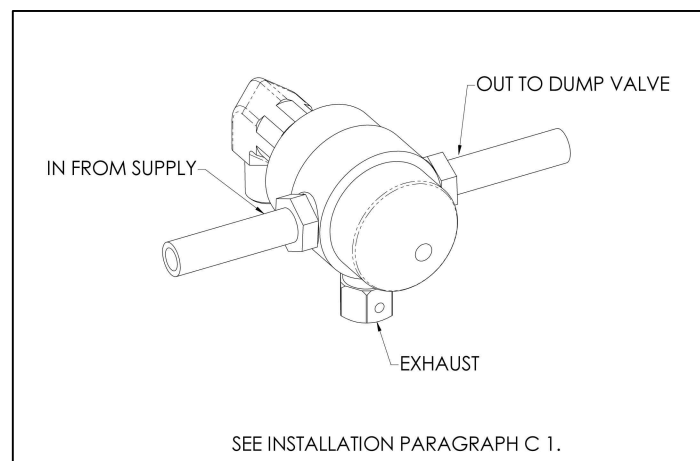

Model 3100

Installation, Operation and Maintenance Instructions

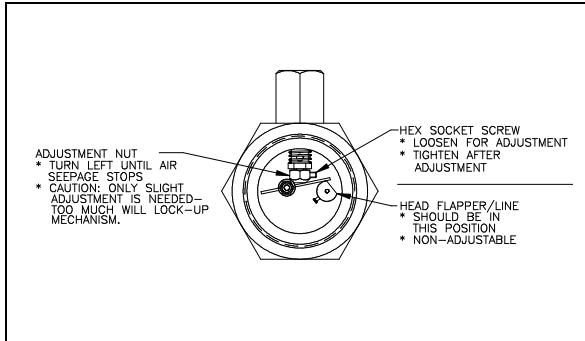

Figure 1

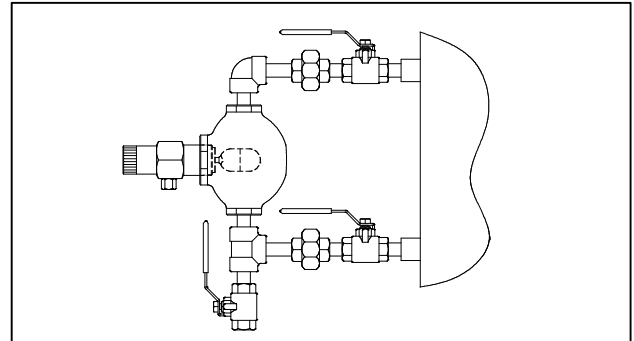

Figure 2

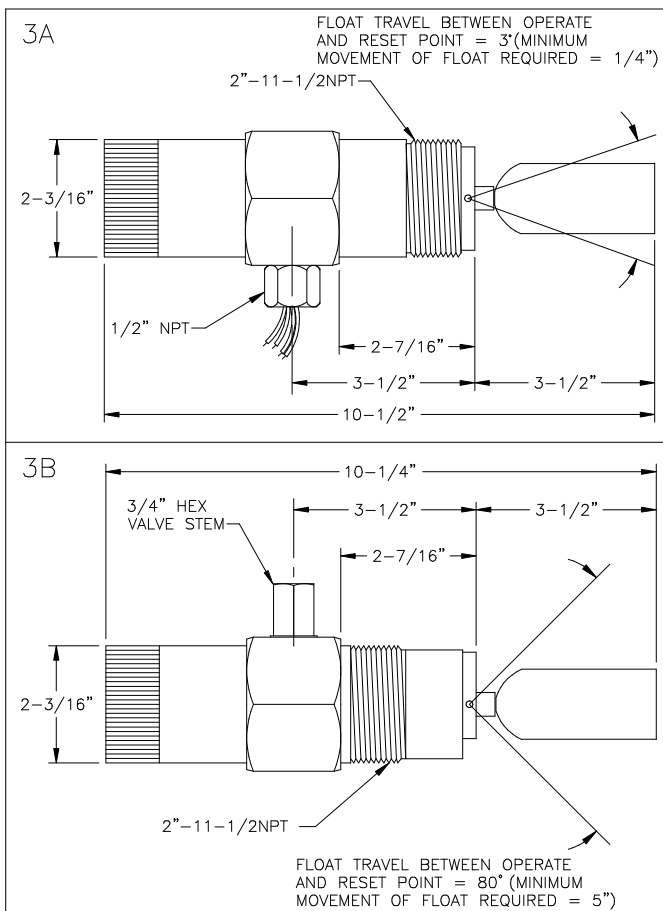

Figure 3

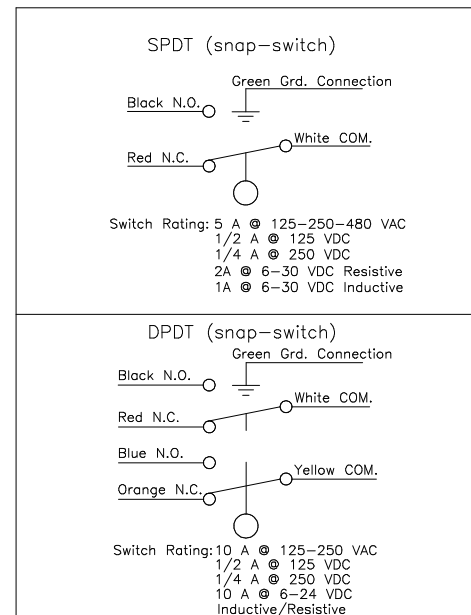

Figure 4