

The Model 5520 is a durable and reliable control valve, well suited for throttling or on/off control of non-lubricating, viscous, or other hard-to-handle fluids. The Model 5520 is used over a broad range of pressure drops and temperatures where accurate and reliable control is required. This valve is available in a wide variety of integral end connection styles, and comes complete with a pneumatic spring return fail-open or fail-close diaphragm actuator.

Features:

- **Rugged Construction** - The heavy-duty steel body / bonnet constructions enable the Model 5520 to provide reliable service in harsh industrial environments.
- **Optimized Flow Path** - Engineered with wide flow passages for maximized flow capacities.
- **Variety of Trim Materials** - Available with 316 SST, or 17-4PH SST plug / cage / seat materials. Hardened seating surfaces (Alloy 6 for cage control or tungsten carbide for plug control) are available for erosive / abrasive services and TFE soft seating surface is available for tight shutoff requirements.
- **Variety of Trim Designs** - Available with equal percentage, linear, or quick opening flow characteristic for cage control and modified percent characteristic for plug control. Anti-cavitation or noise abatement trim sets are also available (cage control design only).
- **Balanced Trim Design** - The pressure-balanced plug reduces actuator thrust requirements, enabling cost savings on the valve actuator.
- **Excellent Shutoff Performance** - Zero leakage (ANSI Class VI) is achieved with the TFE soft seating trim option.
- **Spring-loaded Packing** - Packing is "Live Loaded" by means of a load spring so the packing does not need to be constantly adjusted.
- **Simple Maintenance** - The design of the Model 5520 allows for fast and easy inspection or replacement of the trim without removing the valve from the line. Special tools are not required.



Specifications

Available Body Sizes

2" and 3"

End Connections / Pressure Ratings¹

FNPT ²	3750 psig (259 bar)
150# RF	290 psig (20 bar)
300# RF	750 psig (52 bar)
600# RF	1500 psig (103 bar)
600# RTJ	1500 psig (103 bar)
900# RF	2250 psig (155 bar)
900# RTJ	2250 psig (155 bar)
1500# RF	3750 psig (259 bar)
1500# RTJ	3750 psig (259 bar)

Flow Characteristics

Equal Percent (Cage Control)
 Linear (Cage Control)
 Quick Opening (Cage Control)
 Anti-cavitation (Cage Control)
 Noise Abatement (Cage Control)
 Modified Percent (Plug Control)

Flow Coefficients

See Tables 1A through 1C

Allowable Pressure Drops

See Tables 2A through 2D

Temperature Limits

Standard Valve Configuration:
 • -20 to 180° F (-29 to 82° C)

Materials of Construction

See Tables 3A and 3B

Leakage Rates

Metal-to-Metal Seating	ANSI Leakage Class
0.25" - 0.75"	IV
1.00"	III
1.5" - 6.0"	IV
Soft Seating	ANSI Leakage Class
All Sizes	VI

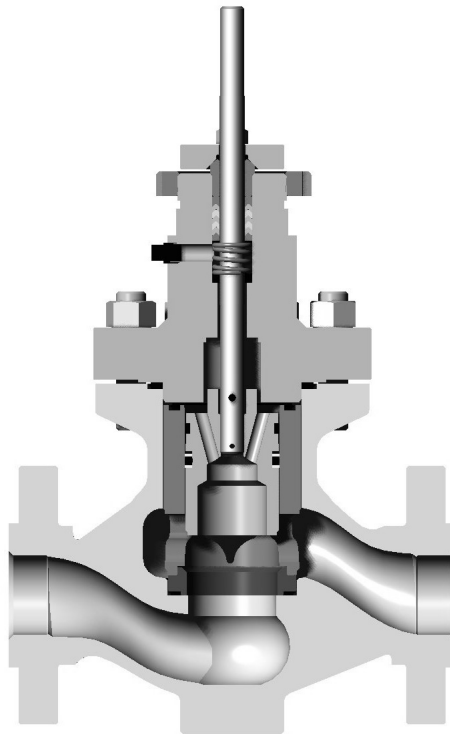

Figure 2. Sectional View

1. Pressure ratings @ 100°F (38°C).
2. 2" valve body only.

Table 1A. Flow Coefficients (C_V), Modified Percent and Quick-Opening

Body Size	Orifice Size	Valve Opening (% Travel)									
		10	20	30	40	50	60	70	80	90	100
2"	0.25"	.284	.506	.657	.767	.875	.989	1.10	1.20	1.32	1.43
	0.38"	.311	.621	.942	1.28	1.64	2.07	2.51	2.93	3.35	3.70
	0.50"	.592	1.17	1.76	2.34	2.95	3.70	4.57	5.50	5.95	6.08
	0.75"	.882	1.76	2.76	3.82	5.53	6.57	8.49	10.8	15.0	16.2
	1.00"	1.01	2.02	3.14	5.07	9.68	11.9	14.9	17.2	19.3	20.9
	1.5"	4.74	7.67	9.53	12.9	18.4	24.9	33.6	44.0	53.4	59.5
	2.0"	5.01	11.0	20.3	33.8	48.9	61.4	67.2	69.5	70.8	71.6
3"	0.25"	.284	.506	.657	.767	.875	.989	1.10	1.20	1.32	1.43
	0.38"	.311	.621	.942	1.28	1.64	2.07	2.51	2.93	3.35	3.70
	0.50"	.592	1.17	1.76	2.34	2.95	3.70	4.57	5.50	5.95	6.08
	0.75"	.882	1.76	2.76	3.82	5.53	6.57	8.49	10.8	15.0	16.2
	1.00"	1.01	2.02	3.14	5.07	9.68	11.9	14.9	17.2	19.3	20.9
	1.5"	4.74	7.67	9.53	12.9	18.4	26.2	35.6	46.2	57.0	65.1
	2.0"	5.01	9.85	16.6	30.6	47.2	62.9	77.0	88.8	96.4	101
	3.0"	6.15	14.9	27.7	52.5	80.3	104	118	124	128	129

Table 1B. Flow Coefficients (C_V), Equal Percentage

Body Size	Orifice Size	Valve Opening (% Travel)									
		10	20	30	40	50	60	70	80	90	100
2"	1.5"	1.03	1.52	2.15	2.89	4.08	6.52	9.85	15.1	21.7	27.4
	2.0"	1.20	2.54	4.75	7.84	12.6	19.2	28.8	40.1	50.4	62.2
3"	2.0"	1.40	2.73	4.96	8.12	12.8	20.4	32.6	49.7	71.6	90.4
	3.0"	2.95	5.89	8.76	16.2	26.9	44.2	68.1	92.6	111	124

Table 1C. Flow Coefficients (C_V), Anti-Cavitation (linear characteristic)

Body Size	Orifice Size	Valve Opening (% Travel)									
		10	20	30	40	50	60	70	80	90	100
2"	1.5"	0.47	0.58	2.03	4.82	7.46	10.2	12.5	14.6	16.6	18.0
	2.0"	0.89	1.09	3.84	9.11	14.1	19.3	23.6	27.5	31.4	34.0
3"	3.0"	1.97	2.40	8.47	20.1	31.1	42.7	52.0	60.7	69.3	75.1

Table 2A. Plug Control Allowable Pressure Drops, PSID - No. 70 Actuator, Direct Acting (Fail Open), Flow Up

Trim Size	Air to Diaphragm, psig			
	18	20	33	35
1.5"	880	1300	1560	2260
2.0"	700	1040	1260	1800
3.0"	470	830	970	1270

Table 2B. Plug Control Allowable Pressure Drops, PSID - No. 70 Actuator, Reverse Acting (Fail Close), Flow Up

Trim Size	Initial Actuator Spring Setting ¹ , psig						
	3	6	9	6	9	12	15
	(3-15 spring)			(6-30 spring)			
1.5"	980	1260	1600	940	1280	1450	1850
2.0"	890	1100	1300	850	1120	1160	1560
3.0"	520	660	910	500	680	860	1290

Table 2C. Cage Control Allowable Pressure Drops, PSID - No. 70 Actuator, Direct Acting (Fail Open), Flow Down

Trim Size	Air to Diaphragm, psig			
	18	20	33	35
1.5"	330	720	3280	3750
2.0"	280	670	3180	3550
3.0"	180	570	2950	3350

Table 2D. Cage Control Allowable Pressure Drops, PSID - No. 70 Actuator, Reverse Acting (Fail Close), Flow Down

Trim Size	Initial Actuator Spring Setting ¹ , psig						
	3	6	9	6	9	12	15
	(3-15 spring)			(6-30 spring)			
1.5"	320	920	1520	800	1400	2100	3350
2.0"	270	850	1440	730	1320	2000	3200
3.0"	185	750	1300	640	1190	1850	3000

1. Initial Actuator Spring Setting is the signal pressure to the diaphragm required to initially lift the plug from the valve seat, while the valve is not in service. (Sometimes referred to as "bench set".)

Table 3A. Materials of Construction

Part	Material	Temperature Limits	
		°F	°C
Body	WCC Steel	-20 to 1000	-29 to 538
	316 SST	-50 to 1000	-45 to 538
Bonnet	A105 Forged Carbon Steel	-20 to 1000	-29 to 538
	CF8M Forged Carbon Steel	-50 to 1000	-45 to 538
Valve Stem	316 Stainless Steel	-50 to 1000	-45 to 538
Packing	PTFE V-Ring	-50 to 400	-45 to 204
	Graphoil	-50 to 750	-45 to 400
Actuator Housing	Steel	-20 to 1000	-29 to 538
Actuator Spring	Steel	-20 to 1000	-29 to 538
Diaphragm	Nylon-Reinforced Buna-N	-20 to 200	-29 to 93

Table 3B. Materials of Construction - Trim Options

Trim Code	Cage	Guide	Plug	Seat	Seal Ring ⁽⁷⁾
1 ^(1,2)	17-4PH SST (H1150M)	---	17-4PH SST (H1150M)	17-4PH SST (H1150M)	TFE
2 ⁽⁵⁾	316 SST	316 SST	316 SST with tungsten carbide insert	316 SST with tungsten carbide seating surface	TFE
3 ⁽³⁾	316 SST	316 SST	316 SST	316 SST	TFE
6 ⁽⁴⁾	17-4PH SST (H1150M)	---	316 SST with Alloy 6 hard-faced seating surface	316 SST with Alloy 6 hard-faced seating surface	TFE
8 ⁽⁶⁾	316 SST	316 SST	316 SST with TFE insert	316 SST with TFE insert	TFE

- Standard material combination for Cage Control trim design.
- Standard material combination for Plug Control trim design, sizes 1" and smaller.
- Standard material combination for Plug Control trim design, sizes greater than 1".
- Available for Cage Control trim only.
- Available for Plug Control trim only.
- For Cage Control trim, TFE insert is part of the seat. For Plug Control trim, TFE insert is part of the plug.
- Consult Factory for temperature requirements above 400°F.

HOW TO ORDER

If Valve Specifics are Known:

1. Specify Valve Size with Model 5520.
(Example: 3" 5520)
2. Locate the product model code on the back page of this bulletin and select the proper code corresponding to the specifications required.
3. Call Mallard Control or your local representative with the valve size, model, and model code for pricing and delivery.

If Valve Specifics are Unknown:

1. Collect as much information about the application as possible per the following guidelines:
 - A. Valve application (i.e. suction, back pressure, pressure reducing, dumping, recycle, etc.)
 - B. Media being controlled (i.e. water, oil, natural gas, carbon dioxide, steam, etc.)
 - C. Specific gravity
 - D. Operating temperature
 - E. Shut-off pressure(s)
 - F. Inlet pressure(s)
 - G. Outlet pressure(s) or pressure drop(s)
 - H. Flow rate(s)
 - I. Actuator action, fail open or close
 - J. Accessories (if any)
2. Call Mallard Control or your local representative with the information for assistance in valve sizing, model code development, pricing, and delivery.

Valve Body Dimensions, inches (mm)

Body End Connection Style	2"			3"				
	A	B Max.	C	A	B Max.	C		
FNPT	11.25 (286)	5.38 (136)	9.00 (228)					
BWE	11.25 (286)							
SWE	11.25 (286)							
150# RF	10.00 (254)					11.75 (298)		
300# RF	10.50 (266)					12.50 (317)		
600# RF	11.25 (286)					13.25 (336)		
600# RTJ	11.38 (289)					13.38 (339)	6.75 (171)	9.25 (235)
900# RF	14.75 (374)					15.50 (393)		
900# RTJ	14.88 (378)					15.62 (397)		
1500# RF	14.75 (374)					18.12 (460)		
1500# RTJ	14.88 (378)					18.25 (463)		

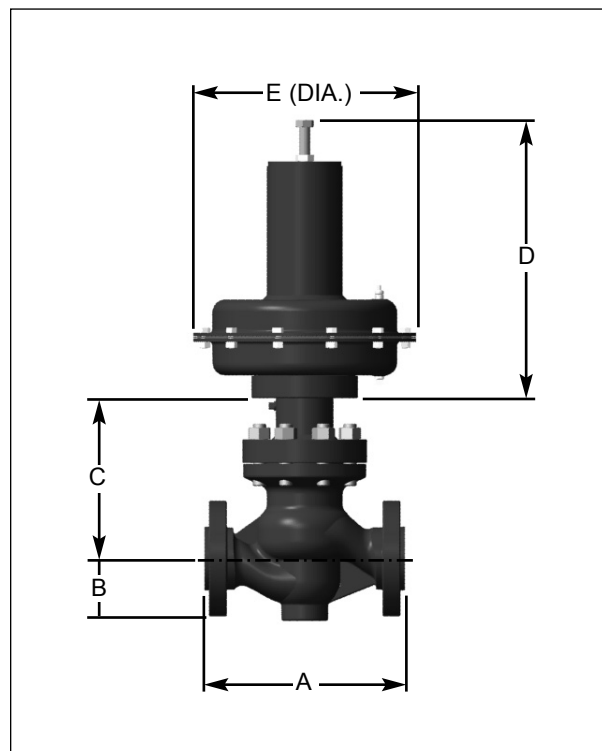

Actuator Dimensions, inches (mm)

Actuator Size	D		E	Boss Size
	Direct	Reverse		
No. 70	18.0 (457.2)	15.6 (396.2)	12.50 (317)	2.81 (71)

Model Number Information

Sample Model Number: 5520 - **2 F 6 - G 73 R S - 3 A E**

BODY SIZE		CODE
2"		2
3"		3
END CONNECTIONS		CODE
Female NPT		S
Raised Face (RF) Flange		F
Ring Type Joint (RTJ) Flange		J
ANSI CLASS (PRESSURE RATING)		CODE
150 (275 psig)		1
300 (740 psig)		3
600 (1480 psig)		6
900 (2220 psig)		9
1500 (3750 psig)		5
MATERIALS OF CONSTRUCTION		CODE
Carbon Steel - Standard Service		-
Carbon Steel - High Temperature Service		H
Carbon Steel - NACE MR-01-75		N
BODY STYLE		CODE
Globe		G
Globe with Drain		D
Globe with Pressure Connection Ports		P
ACTUATOR SELECTION		CODE
No. 70 Actuator with 3-15 Spring		73
No. 70 Actuator with 6-30 Spring		76
ACTUATOR TYPE		CODE
Reverse Acting (spring closes/air opens)		R
Direct Acting (spring opens/air closes)		D
GASKET MATERIAL		CODE
304/Grafoil - Standard		S
Inconel/Grafoil - NACE MR-01-75		N
TRIM MATERIAL		CODE
17-4PH SST Cage, Plug and Seat Ring		1
316 SST Cage, Plug, and Seat Ring with Tungsten Carbide Seating Surfaces		2
316 SST Cage, Plug, and Seat Ring		3
17-4PH SST Cage / 316 SST Plug and Seat Ring with Alloy 6 Hard-faced Seating Surfaces		6
316 SST Cage, Plug, and Seat Ring with TFE Soft-Seal Insert		8
TRIM SIZE		CODE
Full Port		A
Reduced Port, one size down (3" body X 2" trim, 2" body X 1.5" trim)		B
Reduced Port, two sizes down (3" body X 1.5" trim)		C
Reduced Port, three sizes down (3" body X 1" trim)		D
1/4"		2
3/8"		3
1/2"		4
3/4"		6
1"		8
TRIM CHARACTERISTIC		CODE
Equal Percentage		E
Linear		L
Quick Opening (on/off)		Q
Anti-cavitation		C
Noise Abatement		D
Modified Percent		M

While this information is presented in good faith and believed to be accurate, Mallard Control Company does not guarantee results based upon such information. Mallard Control Company reserves the right to change the design or specifications of these products without notice.

Mallard Control Company, Inc.

4970 Washington Boulevard
 Beaumont, Texas, USA 77707
 409 842-5392 Phone
 409 842-8165 FAX
 www.MallardControl.com