



1.0 GENERAL	2
<i>Model Number Information</i>	2
<i>Features</i>	3
<i>Specifications</i>	4
Table 1A. Flow Coefficients (C _v), Modified Percent and Quick-Opening	5
Table 1B. Flow Coefficients (C _v), Equal Percentage.....	5
Table 1C. Flow Coefficients (C _v), Anti-Cavitation (linear characteristic).....	5
Table 2A. Plug Control Allowable Pressure Drops, PSID - No. 70 Actuator, Direct Acting (Fail Open), Flow Up.....	5
Table 2B. Plug Control Allowable Pressure Drops, PSID - No. 70 Actuator, Reverse Acting (Fail Close), Flow Up.....	6
Table 2C. Cage Control Allowable Pressure Drops, PSID - No. 70 Actuator, Direct Acting (Fail Open), Flow Down	6
Table 2D. Cage Control Allowable Pressure Drops, PSID - No. 70 Actuator, Reverse Acting (Fail Close), Flow Down.....	6
<i>Materials of Construction</i>	6
2.0 HOW TO ORDER	8
<i>Valve Body Dimensions, inches (mm)</i>	8
<i>Actuator Dimensions, inches (mm)</i>	8
3.0 INSTALLATION	9
4.0 MAINTENANCE	10
4.1 Trim Replacement	10
4.2 Packing Replacement	10
Table 4. Torque Values (Foot Pounds).....	11
4.3 Actuator Diaphragm Replacement	11
4.4 Preventive Maintenance	11
4.5 Troubleshooting	12

Model 5520

Installation, Operation and Maintenance Instructions

1.0 GENERAL

Model Number Information

Model Number Information

Sample Model Number: 5520 - 2 F 6 - G 73 R S - 3 A E

BODY SIZE		CODE
2"		2
3"		3
END CONNECTIONS		CODE
Female NPT		S
Raised Face (RF) Flange		F
Ring Type Joint (RTJ) Flange		J
ANSI CLASS (PRESSURE RATING)		CODE
150 (275 psig)		1
300 (740 psig)		3
600 (1480 psig)		6
900 (2220 psig)		9
1500 (3750 psig)		5
MATERIALS OF CONSTRUCTION		CODE
Carbon Steel - Standard Service		-
Carbon Steel - High Temperature Service		H
Carbon Steel - NACE MR-01-75		N
BODY STYLE		CODE
Globe		G
Globe with Drain		D
Globe with Pressure Connection Ports		P
ACTUATOR SELECTION		CODE
No. 70 Actuator with 3-15 Spring		73
No. 70 Actuator with 6-30 Spring		76
ACTUATOR TYPE		CODE
Reverse Acting (spring closes/air opens)		R
Direct Acting (spring opens/air closes)		D
GASKET MATERIAL		CODE
304/Grafloil - Standard		S
Inconel/Grafloil - NACE MR-01-75		N
TRIM MATERIAL		CODE
17-4PH SST Cage, Plug and Seat Ring		1
316 SST Cage, Plug, and Seat Ring with Tungsten Carbide Seating Surfaces		2
316 SST Cage, Plug, and Seat Ring		3
17-4PH SST Cage / 316 SST Plug and Seat Ring with Alloy 6 Hard-faced Seating Surfaces		6
316 SST Cage, Plug, and Seat Ring with TFE Soft-Seat Insert		8
TRIM SIZE		CODE
Full Port		A
Reduced Port, one size down (3" body X 2" trim, 2" body X 1.5" trim)		B
Reduced Port, two sizes down (3" body X 1.5" trim)		C
Reduced Port, three sizes down (3" body X 1" trim)		D
1/4"		2
3/8"		3
1/2"		4
3/4"		6
1"		8
TRIM CHARACTERISTIC		CODE
Equal Percentage		E
Linear		L
Quick Opening (on/off)		Q
Anti-cavitation		C
Noise Abatement		D
Modified Percent		M

Features

The Model 5520 is a durable and reliable control valve, well suited for throttling or on/off control of non-lubricating, viscous, or other hard-to-handle fluids. The Model 5520 is used over a broad range of pressure drops and temperatures where accurate and reliable control is required. This valve is available in a wide variety of integral end connection styles, and comes complete with a pneumatic spring return fail-open or fail-close diaphragm actuator.

Features:

- **Rugged Construction** - The heavy-duty steel body / bonnet constructions enable the Model 5520 to provide reliable service in harsh industrial environments.
- **Optimized Flow Path** - Engineered with wide flow passages for maximized flow capacities.
- **Variety of Trim Materials** - Available with 316 SST, or 17-4PH SST plug / cage / seat materials. Hardened seating surfaces (Alloy 6 for cage control or tungsten carbide for plug control) are available for erosive / abrasive services and TFE soft seating surface is available for tight shutoff requirements.
- **Variety of Trim Designs** - Available with equal percentage, linear, or quick opening flow characteristic for cage control and modified percent characteristic for plug control. Anti-cavitation or noise abatement trim sets are also available (cage control design only).
- **Balanced Trim Design** - The pressure-balanced plug reduces actuator thrust requirements, enabling cost savings on the valve actuator.
- **Excellent Shutoff Performance** - Zero leakage (ANSI Class VI) is achieved with the TFE soft seating trim option.
- **Spring-loaded Packing** - Packing is "Live Loaded" by means of a load spring so the packing does not need to be constantly adjusted.
- **Simple Maintenance** - The design of the Model 5520 allows for fast and easy inspection or replacement of the trim without removing the valve from the line. Special tools are not required.



Model 5520

Installation, Operation and Maintenance Instructions

Specifications

Specifications

Available Body Sizes
2" and 3"

End Connections / Pressure Ratings¹

FNPT ²	3750 psig (259 bar)
150# RF	290 psig (20 bar)
300# RF	750 psig (52 bar)
600# RF	1500 psig (103 bar)
600# RTJ	1500 psig (103 bar)
900# RF	2250 psig (155 bar)
900# RTJ	2250 psig (155 bar)
1500# RF	3750 psig (259 bar)
1500# RTJ	3750 psig (259 bar)

Flow Characteristics

Equal Percent (Cage Control)
Linear (Cage Control)
Quick Opening (Cage Control)
Anti-cavitation (Cage Control)
Noise Abatement (Cage Control)
Modified Percent (Plug Control)

Flow Coefficients

See Tables 1A through 1C

Allowable Pressure Drops

See Tables 2A through 2D

Temperature Limits

Standard Valve Configuration:
• -20 to 400° F (-29 to 204° C)

Materials of Construction

See Tables 3A and 3B

Leakage Rates

Metal-to-Metal Seating	ANSI Leakage Class
0.25" - 0.75"	IV
1.00"	III
1.5" - 6.0"	IV
Soft Seating	ANSI Leakage Class
All Sizes	VI

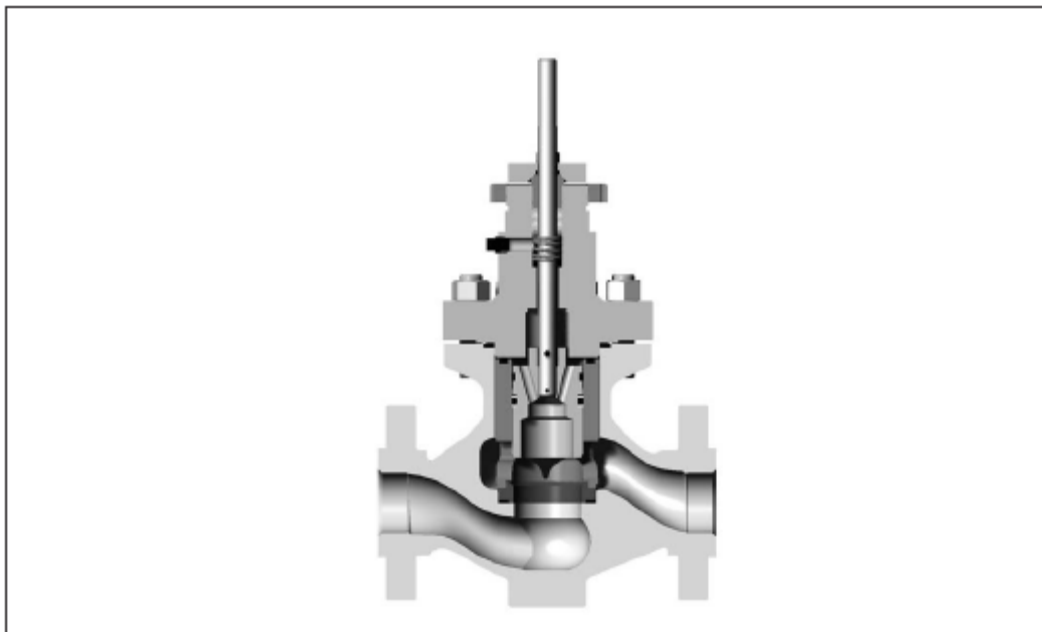

Figure 2. Sectional View

1. Pressure ratings @ 100°F (38°C).
2. 2" valve body only.

Table 1A. Flow Coefficients (C_v), Modified Percent and Quick-Opening

Body Size	Orifice Size	Valve Opening (% Travel)									
		10	20	30	40	50	60	70	80	90	100
2"	0.25"	.284	.506	.657	.767	.875	.989	1.10	1.20	1.32	1.43
	0.38"	.311	.621	.942	1.28	1.64	2.07	2.51	2.93	3.35	3.70
	0.50"	.592	1.17	1.76	2.34	2.95	3.70	4.57	5.50	5.95	6.08
	0.75"	.882	1.76	2.76	3.82	5.53	6.57	8.49	10.8	15.0	16.2
	1.00"	1.01	2.02	3.14	5.07	9.68	11.9	14.9	17.2	19.3	20.9
	1.5"	4.74	7.67	9.53	12.9	18.4	24.9	33.6	44.0	53.4	59.5
	2.0"	5.01	11.0	20.3	33.8	48.9	61.4	67.2	69.5	70.8	71.6
3"	0.25"	.284	.506	.657	.767	.875	.989	1.10	1.20	1.32	1.43
	0.38"	.311	.621	.942	1.28	1.64	2.07	2.51	2.93	3.35	3.70
	0.50"	.592	1.17	1.76	2.34	2.95	3.70	4.57	5.50	5.95	6.08
	0.75"	.882	1.76	2.76	3.82	5.53	6.57	8.49	10.8	15.0	16.2
	1.00"	1.01	2.02	3.14	5.07	9.68	11.9	14.9	17.2	19.3	20.9
	1.5"	4.74	7.67	9.53	12.9	18.4	26.2	35.6	46.2	57.0	65.1
	2.0"	5.01	9.85	16.6	30.6	47.2	62.9	77.0	88.8	96.4	101
3.0"	6.15	14.9	27.7	52.5	80.3	104	118	124	128	129	

Table 1B. Flow Coefficients (C_v), Equal Percentage

Body Size	Orifice Size	Valve Opening (% Travel)									
		10	20	30	40	50	60	70	80	90	100
2"	1.5" 2.0"	1.03	1.52	2.15	2.89	4.08	6.52	9.85	15.1	21.7	27.4
		1.20	2.54	4.75	7.84	12.6	19.2	28.8	40.1	50.4	62.2
3"	2.0" 3.0"	1.40	2.73	4.96	8.12	12.8	20.4	32.6	49.7	71.6	111
		2.95	5.89	8.76	16.2	26.9	44.2	68.1	92.6	124	124

Table 1C. Flow Coefficients (C_v), Anti-Cavitation (linear characteristic)

Body Size	Orifice Size	Valve Opening (% Travel)									
		10	20	30	40	50	60	70	80	90	100
2"	1.5" 2.0"	0.47	0.58	2.03	4.82	7.46	10.2	12.5	14.6	16.6	18.0
		0.89	1.09	3.84	9.11	14.1	19.3	23.6	27.5	31.4	34.0
3"	3.0"	1.97	2.40	8.47	20.1	31.1	42.7	52.0	60.7	69.3	75.1

Table 2A. Plug Control Allowable Pressure Drops, PSID - No. 70 Actuator, Direct Acting (Fail Open), Flow Up

Trim Size	Air to Diaphragm, psig			
	18	20	33	35
1.5"	880	1300	1560	2260
2.0"	700	1040	1260	1800
3.0"	470	830	970	1270

Model 5520

Installation, Operation and Maintenance Instructions

Table 2B. Plug Control Allowable Pressure Drops, PSID - No. 70 Actuator, Reverse Acting (Fail Close), Flow Up

Trim Size	Initial Actuator Spring Setting ¹ , psig						
	3	6	9	6	9	12	15
	(3-15 spring)			(6-30 spring)			
1.5"	980	1260	1600	940	1280	1450	1850
2.0"	890	1100	1300	850	1120	1160	1560
3.0"	520	660	910	500	680	860	1290

Table 2C. Cage Control Allowable Pressure Drops, PSID - No. 70 Actuator, Direct Acting (Fail Open), Flow Down

Trim Size	Air to Diaphragm, psig			
	18	20	33	35
1.5"	330	720	3280	3750
2.0"	280	670	3180	3550
3.0"	180	570	2950	3350

Table 2D. Cage Control Allowable Pressure Drops, PSID - No. 70 Actuator, Reverse Acting (Fail Close), Flow Down

Trim Size	Initial Actuator Spring Setting ¹ , psig						
	3	6	9	6	9	12	15
	(3-15 spring)			(6-30 spring)			
1.5"	320	920	1520	800	1400	2100	3350
2.0"	270	850	1440	730	1320	2000	3200
3.0"	185	750	1300	640	1190	1850	3000

1. Initial Actuator Spring Setting is the signal pressure to the diaphragm required to initially lift the plug from the valve seat, while the valve is not in service. (Sometimes referred to as "bench set".)

Materials of Construction

Part	Material	Temperature Limits	
		°F	°C
Body	WCC Steel	-20 to 1000	-29 to 538
	316 SST	-50 to 1000	-45 to 538
Bonnet	A105 Forged Carbon Steel	-20 to 1000	-29 to 538
	CF8M Forged Carbon Steel	-50 to 1000	-45 to 538
Valve Stem	316 Stainless Steel	-50 to 1000	-45 to 538
Packing	PTFE V-Ring	-50 to 400	-45 to 204
	Graphoil	-50 to 750	-45 to 400
Actuator Housing	Steel	-20 to 1000	-29 to 538
Actuator Spring	Steel	-20 to 1000	-29 to 538
Diaphragm	Nylon-Reinforced Buna-N	-20 to 200	-29 to 93

Table 3A. Materials of Construction - Trim Options

Trim Code	Cage	Guide	Plug	Seat	Seal Ring(7)
1(1,2)	17-4PH SST (H1150M)	---	17-4PH SST (H1150M)	17-4PH SST (H1150M)	TFE
2(5)	316 SST	316 SST	316 SST with tungsten carbide insert	316 SST with tungsten carbide seating surface	TFE
3(3)	316 SST	316 SST	316 SST	316 SST	TFE
6(4)	17-4PH SST (H1150M)	---	316 SST with Alloy 6 hard-faced seating surface	316 SST with Alloy 6 hard-faced seating surface	TFE
8(6)	316 SST	316 SST	316 SST with TFE insert	316 SST with TFE insert	TFE

1. Standard material combination for Cage Control trim design.
2. Standard material combination for Plug Control trim design, sizes 1" and smaller.
3. Standard material combination for Plug Control trim design, sizes greater than 1".
4. Available for Cage Control trim only.
5. Available for Plug Control trim only.
6. For Cage Control trim, TFE insert is part of the seat. For Plug Control trim, TFE insert is part of the plug.
7. Consult Factory for temperature requirements above 400°F.

Model 5520

Installation, Operation and Maintenance Instructions

2.0 HOW TO ORDER

If Valve Specifics are Known:

1. Specify Valve Size with Model 5520.
(Example: 3" 5520)
2. Locate the product model code on the back page of this bulletin and select the proper code corresponding to the specifications required.
3. Call Mallard Control or your local representative with the valve size, model, and model code for pricing and delivery.

If Valve Specifics are Unknown:

1. Collect as much information about the application as possible per the following guidelines:
 - A. Valve application (i.e. suction, back pressure, pressure reducing, dumping, recycle, etc.)
 - B. Media being controlled (i.e. water, oil, natural gas, carbon dioxide, steam, etc.)
 - C. Specific gravity
 - D. Operating temperature
 - E. Shut-off pressure(s)
 - F. Inlet pressure(s)
 - G. Outlet pressure(s) or pressure drop(s)
 - H. Flow rate(s)
 - I. Actuator action, fail open or close
 - J. Accessories (if any)
2. Call Mallard Control or your local representative with the information for assistance in valve sizing, model code development, pricing, and delivery.

Valve Body Dimensions, inches (mm)

Body End Connection Style	2"			3"		
	A	B Max.	C	A	B Max.	C
FNPT	11.25 (286)	5.38 (136)	9.00 (228)			
BWE	11.25 (286)					
SWE	11.25 (286)					
150# RF	10.00 (254)			11.75 (298)	6.75 (171)	9.25 (235)
300# RF	10.50 (266)			12.50 (317)		
600# RF	11.25 (286)			13.25 (336)		
600# RTJ	11.38 (289)			13.38 (339)		
900# RF	14.75 (374)			15.50 (393)		
900# RTJ	14.88 (378)			15.62 (397)		
1500# RF	14.75 (374)			18.12 (460)		
1500# RTJ	14.88 (378)			18.25 (463)		

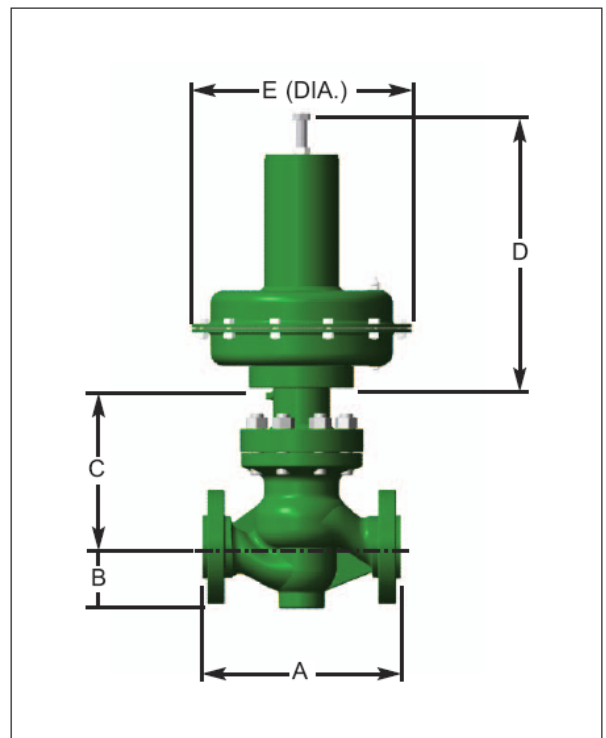

Actuator Dimensions, inches (mm)

Actuator Size	D		E	Boss Size
	Direct	Reverse		
No. 70	18.0 (457.2)	15.6 (396.2)	12.50 (317)	2.81 (71)

3.0 INSTALLATION

1. Prior to valve installation, inspect the unit for damages which might have occurred during shipment and handling. Remove any items covering the process connections of the valve. Inspect the inlet and outlet connections to assure that no debris has become lodged inside the valve.
2. When installing the valve into the pipeline, consult the engineering specifications to ensure that the valve is installed according to the intended flow pattern ("above-the-seat" or "below-the-seat"). As a general rule of thumb, the flow pattern (direction) is "below-the-seat" for throttling applications, and "above-the-seat" for snap (on/off) applications. The following symbol is cast into the valve body to help you determine the correct flow pattern.

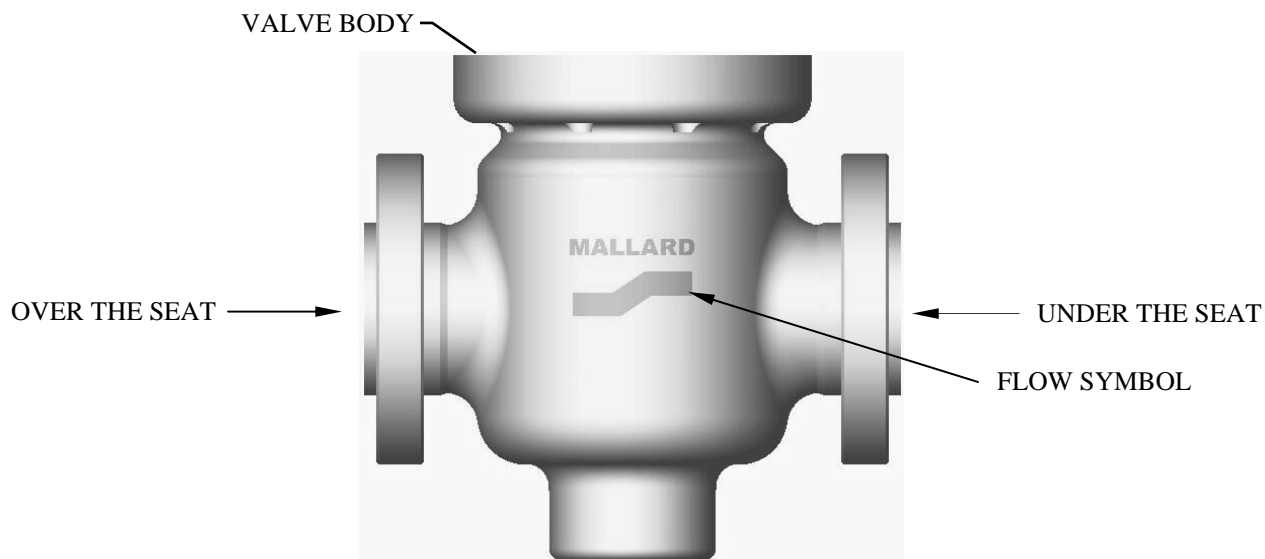

3. Install valve using good piping practices.
4. Do not install the valve in a system where the working pressure might exceed the class rating marked on the nameplate.

WARNING: Working pressure of control valve body does not necessarily reflect the shut-off pressure of which the actuator is capable. Check actuator shut-off charts or call the factory.

5. Connect instrument air to the actuator.
6. Valves with adjustable actuators are **not** shipped with actuator preset.

Reverse (Fail Close) Actuators: To increase shut-off capability, increase spring pre-load by turning spring adjusting screw clockwise. To decrease spring pre-load, turn spring adjusting screw counter-clockwise.

Direct (Fail Open) Actuators: To increase opening capability, increase spring pre-load by turning spring adjusting nut clockwise. To decrease spring pre-load, turn spring adjusting nut counter-clockwise.

Model 5520

Installation, Operation and Maintenance Instructions

4.0 MAINTENANCE

4.1 Trim Replacement

WARNING: System pressure must be bled off to 0 psig or the valve must be isolated with the pressure bled off prior to any maintenance involving disassembly of the valve or valve actuator.

1. Remove air supply from actuator.
2. Remove all actuator spring pre-load on Reverse (spring closing) and Direct (spring opening) actuators prior to starting.
3. Remove the nuts from the bonnet studs.
4. Lift bonnet straight up and off valve body. Valve plug, guide and cage will be attached to the end of the valve stem.
5. Pull the seat and gasket out of seat pocket and lift out of valve body.
6. Clean seat pocket in valve body as required.
7. Insert new Seat and gasket.
8. To disassemble the plug from the stem, drive the retaining pin out of valve plug and unscrew the plug from the valve stem.
9. Slide the plug from the cage and guide.
10. Replace the Teflon O-ring and back-up Ring with new ones.
11. Slide new plug into the cage and guide.
12. Place new guide gasket onto the guide.
13. Screw new plug onto the valve stem until pinning holes line up and drive new retaining pin into place.
14. Install bonnet gasket on top of valve body.
15. Place bonnet assembly with new valve plug onto valve body making sure the bonnet is aligned correctly with the body.
16. Tighten bonnet nuts to recommended torque value in Table 4.
17. Reconnect instrument air supply to actuator.
18. Adjust actuator spring as outlined in Step 6 of Section 2.0, "Installation".

4.2 Packing Replacement

1. Remove air supply from actuator.
2. Remove all actuator spring pre-load on Reverse (spring closing) and Direct (spring opening) actuators prior to starting.
3. Remove the nuts from the bonnet studs.
4. Lift bonnet straight up and off valve body. Valve plug, guide and cage will be attached to the end of the valve stem.
5. Assuming the actuator and stem connector have already been removed, pull the stem from the bonnet on the plug side leaving the plug, guide and cage attached.
6. Unscrew nuts from packing flange.
7. Remove upper packing retainer.
8. Remove Packing washer, spacer, load spring and packing.
9. It may be necessary to use a hook or a rod pushed through from the bottom side to the remove packing taking care not to scratch the wall in the bonnet.
10. Clean any debris from the bonnet and all metal parts.
11. Replace the packing spacer, the packing load spring and packing washer in that order into the bonnet.
12. Place the male "V" packing ring onto the packing washer.
13. Place the "V" packing rings onto the male packing ring. ("V" downward toward the body)
14. Then place the upper packing retainer onto the packing.
15. Replace the packing flange and packing flange nuts. (Do not tighten)
16. Replace guide gasket and slide stem into the bonnet from the bottom.
17. Replace all gaskets.
18. Reinstall bonnet assembly by reversing steps 3-4 of these instructions.
19. Tighten bonnet nuts to recommended torque value in Table 4.
19. Tighten packing flange nuts.

Table 4. Torque Values (Foot Pounds)

Valve Size		ANSI Pressure Class				
		150	300	600	900	1500
2.00"	Stud Size	0.75	0.75	0.75	0.75	0.75
	Torque	75	80	80	175	175
3.00"	Stud Size	0.75	0.75	0.75	0.75	1.00
	Torque	90	90	90	140	275

4.3 Actuator Diaphragm Replacement

- 4.3.1 Direct (Fail Open) and Reverse (Fail Close) Actuators:
1. Remove air supply from actuator.
 2. Remove all spring tension.
 3. Remove screws and nuts around diaphragm housing.
 4. Remove upper diaphragm housing.
 5. If direct remove actuator diaphragm and replace with new diaphragm.
 6. If reverse Remove diaphragm plate nut and/or diaphragm plate. Remove actuator diaphragm and replace with new diaphragm.
 7. Reassemble actuator by reversing steps 1-4.

4.4 Preventive Maintenance

The following preventative maintenance should be performed periodically as dictated by the severity of the application or by maintenance schedule.

- 4.4.1 Valve Body
The internal valve body should be inspected every time trim is replaced, packing is changed, or the actuator is worked on. Under normal operating conditions the valve body should show no signs of wear. If wear is noticed within the valve body from high pressure drops, abrasive flows, or chemical corrosion, the valve body should be replaced to assure safety during valve operation.
- 4.4.2 Valve Trim
Check the valve plug and seat for wear that might be caused by high pressure drops, abrasives in the media, or corrosion. If signs of wear are present, then trim replacement is recommended for optimum valve performance.
- 4.4.3 Packing
Check the "weep" hole in the bonnet for discharge. Discharge is a sign of packing leakage. If discharge is present then packing replacement is recommended.
- 4.4.4 Actuator Assembly
Visually inspect the actuator operation of the valve by observing the travel indicator while the valve is stroking for a smooth, consistent movement. Jerking type movements may indicate a problem within the valve. De-pressurize the valve and inspect it internally.
- Listen for a "hissing" sound during operation. This may indicate a worn seal or diaphragm. Replace any worn seal or diaphragm.

Model 5520

Installation, Operation and Maintenance Instructions

4.5 Troubleshooting

Problem	Possible Cause	Fix
Valve leaks excessively when closed (Section 1.2 defines the Model 5520 leakage rates. Refer to ANSI / FCI 70-2-1976 for control valve allowable leakage classifications.)	<p><u>Reverse Acting:</u> Actuator spring load not sufficient.</p> <p><u>Direct Acting:</u> Inadequate air supply pressure.</p> <p>Debris between the plug and seat preventing tight shut-off.</p> <p>Plug and seat are not sealing.</p> <p>Plug and seat are worn out.</p> <p>Actuator force not enough for shut-off (actuator too small).</p>	<p><u>Reverse Actuator:</u> Increase actuator spring pre-load.</p> <p><u>Direct Acting:</u> Increase air supply pressure but do not exceed maximum rating on nameplate.</p> <p>Remove debris.</p> <p>Re-lap trim.</p> <p>Replace trim.</p> <p>Consult factory or local representative for proper actuator sizing.</p>
Valve will not open	<p><u>Reverse Acting:</u> Not receiving air supply.</p> <p><u>Reverse Acting:</u> Too much spring pre-load.</p> <p><u>Direct Acting:</u> Inadequate spring pre-load.</p> <p>Debris lodged behind valve plug.</p>	<p>Check air supply source and tubing to the actuator connection.</p> <p>Decrease spring pre-load by turning adjusting screw counter-clockwise.</p> <p>Increase spring pre-load by turning adjusting nut clockwise.</p> <p>Remove debris.</p>
Discharge evident from bonnet "weep" hole.	Packing is worn.	Replace packing.
Supply air leaking out of breather plug during operation	Diaphragm is worn out or torn.	Replace diaphragm